



Bilangan Sebutharga/ *Quotation Number*: **QTN/105/2024/2024**

Tarikh Tutup/ *Closing Date*: **2 Disember 2024 @ 2.00 petang**

Sila isikan nama maklumat di bawah / *Please fill in the information below* :

Nama Syarikat / :  
*Company Name*

Nama Pemilik Berdaftar / :  
*Registered Owner*

Alamat Syarikat / :  
*Company Address*

Dimaklumkan Syarikat Tuan / Puan dipelawa untuk memberikan sebutharga bagi barang / perkhidmatan yang disenaraikan di bawah dengan mengisikan ruang sebutharga. / *Please provide a quotation for the following items by filling in the appropriate column.*

18/11/2024

Tarikh/ *Date*

  
T.T. Ketua Bahagian dan Cap/  
*HoS's Signature and Stamp*

Nota:

Borang sebutharga hendaklah di isi dengan maklumat syarikat yang lengkap. Pihak Jabatan tidak akan menerima mana-mana borang yang tidak lengkap dan akan dikira batal.

*Note:*

*The quotation form must be filled with complete company information. The Department will not accept any form that is incomplete and will be considered invalid.*

<b>BIL/ No</b>	<b>KETERANGAN BARANG DAN PERKHIDMATAN/ <i>Description of Items and Services</i></b>	<b>BANYAK/ Quantity</b>	<b>HARGA SEUNIT/ Price Per Unit</b>	<b>JUMLAH/ Total</b>
	<b>TO FABRICATE AND SUPPLY, BOUNDARY MARK STORAGE RACK. AT BENGKEL JABATAN UKUR KG BURONG LEPAS SPG 312 JALAN BENKURONG MASIN.</b>			
1	<p><b><u>FABRICATION WORKS</u></b></p> <p>To fabricate new storage rack for boundary marks stone.</p> <p>All measurements and designs must be in accordance with <b>attachment A</b>.</p> <p>Note: Each set must be able to accommodate as many as 600 boundary marker stones, hence the supplier must ensure the use of sturdy materials. (the thickness of the material is only a recommendation and cannot be less than what has been stated)</p>	6 Set		
2	<p><b><u>PAINTING WORKS</u></b></p> <ul style="list-style-type: none"> <li>• Prepare and sealing applying new <b>one</b> undercoat and <b>two</b> finishing coats <b>Gloss finish</b> to metal surfaces. Use anti rust resistant paint.</li> </ul> <p>Note:</p> <ul style="list-style-type: none"> <li>• Vendor must attend and register at the site visit on the <b>26 November 2024 9.30 am</b> with survey officers in charge in order to determine the extent of work/difficulties of the work as any claim for extra shall not be entertained due to lack of knowledge of site condition.</li> <li>• All measurement Shall be done during the site visit.</li> <li>• Vendor shall liaise and coordinate with survey officers in charge before commencing any work for services involved.</li> <li>• Vendor shall make good to all disturbed affected area.</li> <li>• All work must completed and supply by the <b>end of January 2025</b></li> </ul>	1 Lot		



5. Semua sebutharga mestilah mempunyai Kos, Insuran dan Pengangkutan (CIF) on site dan pemasangan, jika ada. / *All prices must include Cost, Insurance and Freight (CIF) on site and installation, if any.*
6. Sahlaku sebutharga mestilah dinyatakan, jika tidak dinyatakan sebutharga tersebut sah digunakan tanpa had masa. / *The validity of the quotation should be stated. Unless otherwise stated, the quotation is valid for an unlimited period of time.*
7. Pihak pembekal (Syarikat) hendaklah menyenaraikan semua pembekalan barang atau perkhidmatan kerja-kerja yang dilaksanakan secara terperinci di dalam invois mengikut skop yang dinyatakan di dalam dokumen sebutharga atau tawaran. / *The supplier (Company) shall list all supply of goods or services in detail in the invoice according to the scope specified in the quotation.*
8. Bagi kerja-kerja perkhidmatan yang memerlukan pendaftaran Autoriti Kawalan Bangunan dan Industri Pembinaan (ABCI), Kementerian Pembangunan, Negara Brunei Darussalam, pihak pembekal (Syarikat) hendaklah menyertakan salinan **Sijil Pendaftaran Pembekal / Kontraktor** di bawah Autoriti Kawalan Bangunan dan Industri Pembinaan (ABCI), Kementerian Pembangunan, Negara Brunei Darussalam yang masih sah laku. / *For works requiring registration from the Authority on Building Control and Construction Industry (ABCI), the supplier (company) shall provide the **Builder/Contractor Registration Certificate** under ABCi of the Ministry of Development.*
9. Pihak pembekal (Syarikat) hendaklah menyertakan **Sijil Pendaftaran Syarikat** di bawah Bahagian Pendaftaran Syarikat-syarikat dan Nama-nama Perniagaan (ROCBN), Kementerian Kewangan dan *Corporate Registry System* di dalam *One Common Portal*. / *The supplier (Company) shall provide the **Company Registration Certificate** under the Registry of Companies and Business Names (ROCBN) and the Corporate Registry System in the One Common Portal.*
10. Pihak pembekal (Syarikat) akan bertanggungjawab untuk membayar denda ganti rugi jika gagal memberikan perkhidmatan, pembekalan dan penghantaran mengikut spesifikasi yang dinyatakan di dalam sebutharga / kontrak dan mengikut jadual / tempoh yang dipersetujui dengan kadar seperti berikut :

$$\text{Kadar Denda Ganti Rugi (BND / Sehari)} = \frac{15\% \times \text{Jumlah Sebutharga (BND)}}{\text{Tempoh Penyiapan Perkhidmatan / Pembekalan / Penghantaran (Hari)}}$$

*The supplier (Company) shall be liable for paying Liquidated and Ascertained Damages (LAD) if it fails to provide service, supply and delivery in accordance with the specifications stated in the quotation / contract and in accordance with the schedule / agreed period at the following rate:*

$$\text{LAD Rate (BND / Day)} = \frac{15\% \times \text{Total Quotation Value (BND)}}{\text{Duration of Service/ Supply / Delivery (No. of Days)}}$$

11. Bagi sebutharga yang berkaitan dengan IT, Pihak pembekal (Syarikat) akan bertanggungjawab untuk membayar denda ganti rugi jika gagal memberikan

perkhidmatan, pembekalan, penghantaran dan pembuatan sistem mengikut spesifikasi yang dinyatakan di dalam sebutharga / kontrak dan mengikut jadual / tempoh yang dipersetujui dengan kadar 0.1% (1/10 persen) bagi setiap satu hari lewat daripada jumlah harga sebutharga sehingga maksimum 10%

*For Quotation related with IT, the supplier (Company) shall be liable for paying Liquidated and Ascertained Damages (LAD) if it fails to provide service, supply, delivery and system development in accordance with the specifications stated in the quotation / contract and in accordance with the schedule / agreed period at rate 0.1% (one-tenth of a percent) per one day delayed, of the total quotation price, up to a maximum of ten percent (10%).*

12. Bagi sebutharga yang berkaitan dengan Perkhidmatan "Support Services" IT, Jika Pihak Kontraktor (Syarikat) gagal untuk membetulkan kecacatan atau kesilapan dalam dalam tempoh yang diberikan, khususnya "Response Time" dan "Down Time", pihak Kontraktor akan bertanggungjawab untuk membayar denda ganti rugi yang berjumlah bersamaan dengan 0.1% (1/10 persen) daripada jumlah harga "Maintenance and Support Service Charge" bagi setiap 30 minit lewat sehingga maksimum 10%.

*For Quotation related with IT Support Services, If the Contractor (Company) fails to rectify any defect or error within the Response Time and Down Time, the Contractor shall pay as liquidated damages and not as penalty a sum equivalent to 0.1% (one-tenth of a percent) of the Maintenance and Support Services Charges, for every 30 minutes of delay, up to a maximum of ten percent (10%).*

13. Sila kembalikan dan disimpan di **Peti Sebutharga** Tingkat 4, Jabatan Ukur.  
(Please return this form to the **Quotation Box** provided at 4<sup>th</sup> Floor, Survey Department).

Dengan ini saya/kami sebagai pemilik syarikat tidak berpakat sulit dengan Syarikat (Syarikat-Syarikat) lain atau dengan sesiapa dalam menghadapi sebutharga untuk projek yang disebutkan di atas. Kami memahami bahawa berpakat sulit dengan syarikat-syarikat lain adalah suatu kesalahan di bawah **Bab 11, Perintah Persaingan 2015** dan boleh dikenakan penalti kewangan tidak melebihi 10 peratus atau peratusan lain dari perolehan perniagaan bagi setiap tahun pelanggaran bagi tempoh, maksima 3 tahun.

*Herewith, I/We have not colluded with any other company (ies) or any other person or entity in submitting the Tender Proposal for the above-mentioned project. We understand that tender collusion is an offence under **Section 11, Competition Order 2015** and can be liable to a financial penalty of maximum 10 percent or such other percentage of business turnover for each year of infringement for a period, up to a maximum of 3 years.*

---

Tarikh/ Date

---

T.T. dan Cop Pembekal. /  
Supplier's Signature and Stamp

# Attachment A

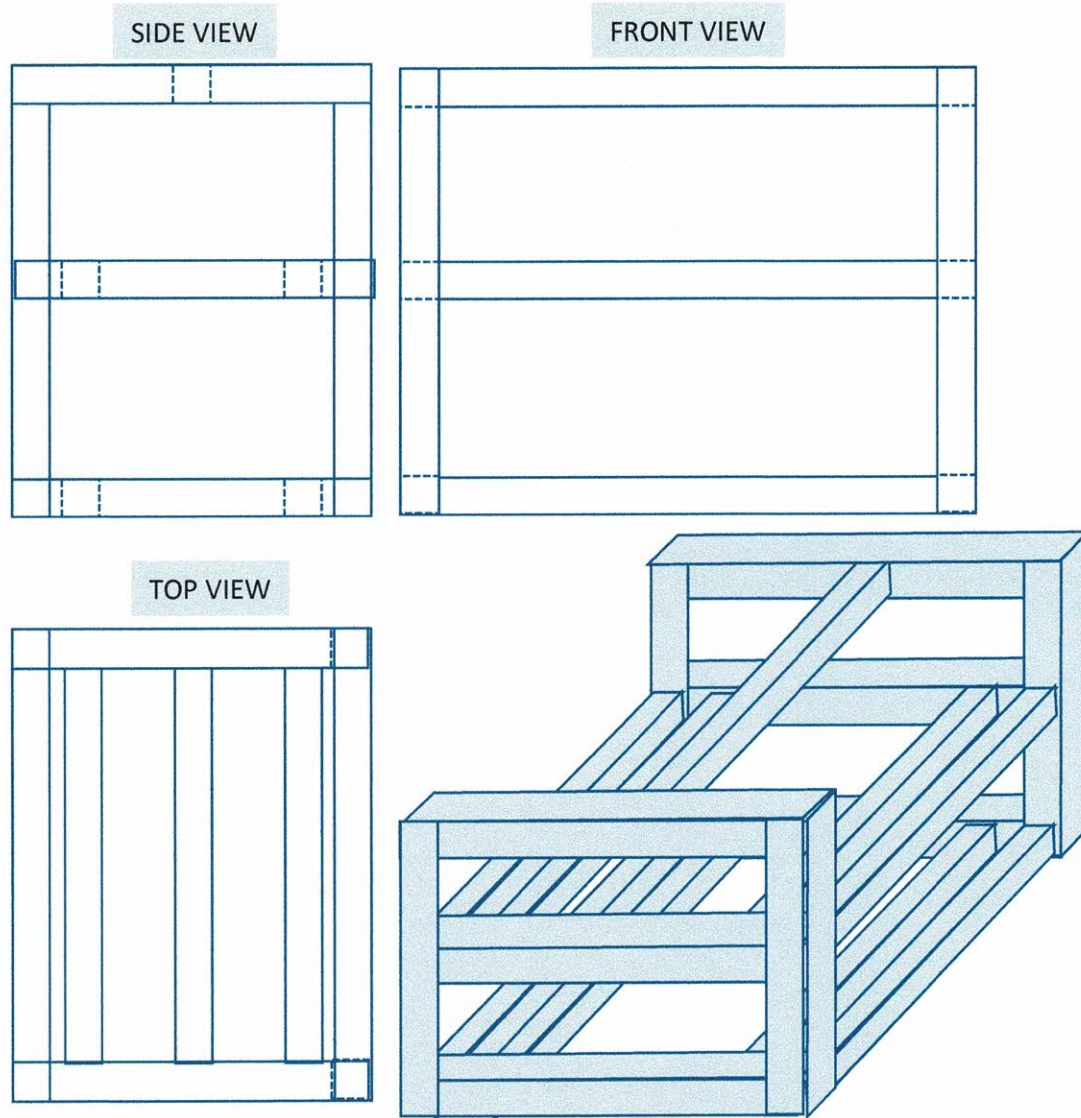

## Materials:

- 3" X 3" hollow 3mm MS Steel.
- Rust resistant paint

FRONT VIEW

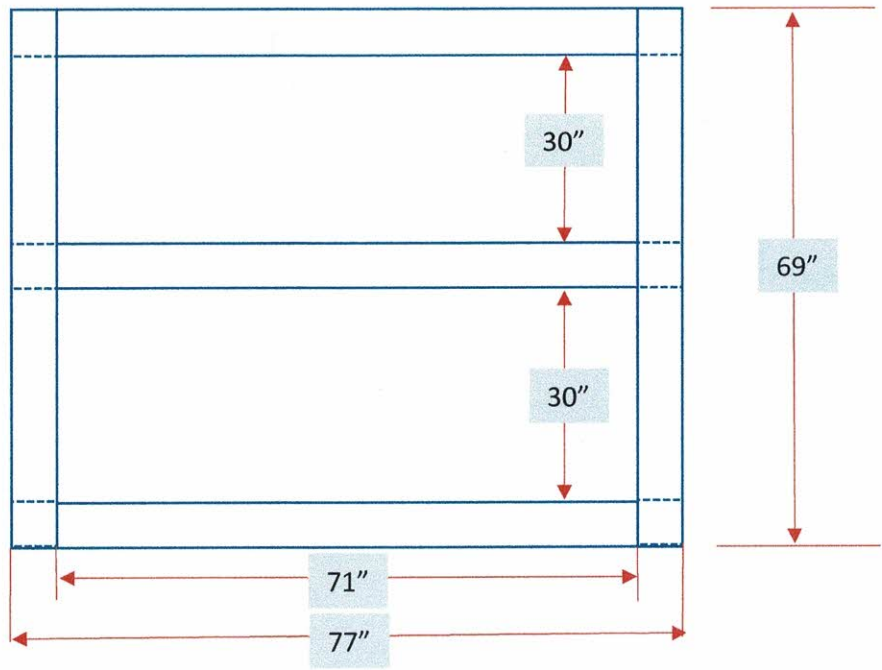

SIDE VIEW

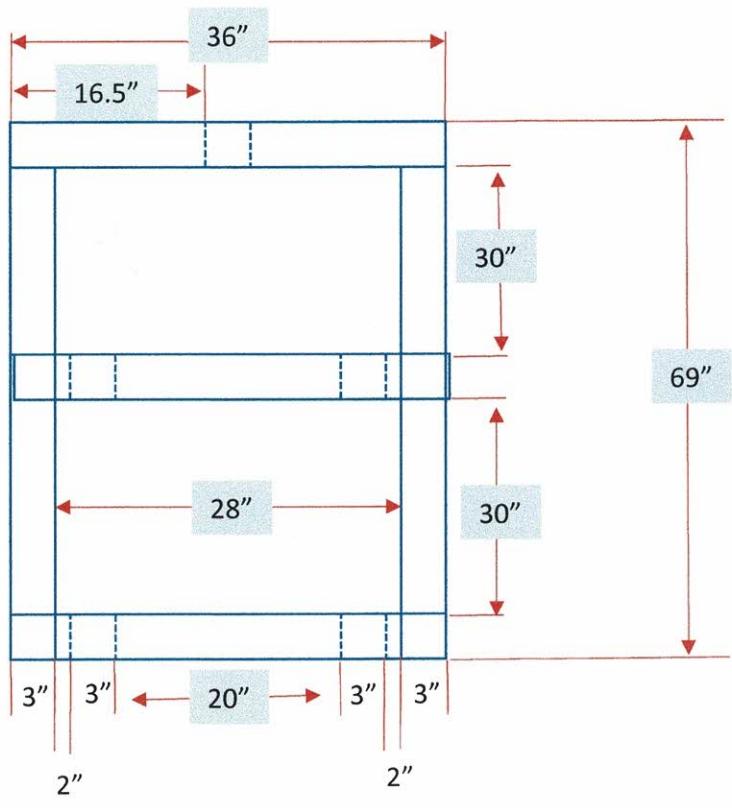



TOP VIEW

